

Model LE Series

ELECTRIC SCISSOR LIFT

Features

65 x 115 in. (1.65 x 2.92 m) Work Platform
Full Time ATC—JLG Automatic Traction Control System
Oscillating Axle
Proportional Direct DC Electric Drive
Proportional Lift Up
110V-AC Receptacle in Platform
240/55-17.5 Foam-Filled Non-Marking Tires
8 x 6V, 370 amp-hr Batteries
3 ft Roll-Out Deck Extension
On-Board Diagnostics with Common JLG Analyzer
Forklift-Able Battery Compartments with Quick Disconnect Couplings
Fold-Down Hand Rails
Moveable, Removable Platform Console Box
23 Amp Automatic, SCR Battery Charger
Battery Charge Indicator in Platform
3 Degree Tilt Indicator Light and Alarm
All Motion Alarm
Manual Descent
Tie Down Lugs
Hourmeter
Horn

Accessories & Options

110V AC Power Pack (Generator)
Flashing Amber Beacon
Sand/Turf Tires
Hydraulic Leveling Jacks
Platform Work Lights
QuikCharge GenSet
All-Wheel Drive



Superior Performance On or Off Slab

- Rugged all-terrain tires and available all-wheel drive
- Full-time Automatic Traction Control and oscillating axle
- Optional hydraulic leveling jacks for uneven terrain

Power to Stay On the Job Longer

- Double the duty cycles of competitive electric scissor lifts
- Exclusive QuikCharge GenSet option provides automatic charging system for continuous operation

High Capacities and Cleaner Operation

- Holds up to 1,000 lb on the platform (Model 3369LE) and 250 lb on the platform extension
- Zero emissions and quiet operation for sensitive indoor applications

JLG

Model LE Series ELECTRIC SCISSOR LIFT

Specifications

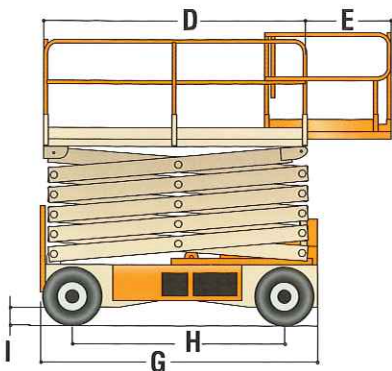
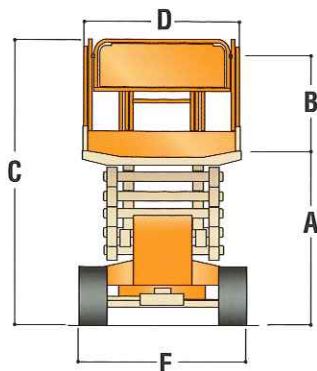

Dimensions

A. Platform Height-Elevated	
3369LE	33 ft (10.06 m)
4069LE	40 ft (12.19 m)
Platform Height-Lowered	
3369LE	5 ft 6.5 in. (1.69 m)
4069LE	5 ft 9 in. (1.75 m)
B. Platform Railing Height	3 ft 7.5 in. (1.10 m)
C. Overall Height-Rails Up	
3369LE	9 ft (2.74 m)
4069LE	9 ft 2.5 in. (2.81 m)
Overall Height-Rails Lowered	
3369LE	6 ft 5 in. (1.96 m)
4069LE	6 ft 7 in. (2.0 m)

D. Platform Size	65 x 115 in. (1.65 x 2.92 m)
E. Platform Extension	3 ft (91 cm)
F. Overall Width	5 ft 9 in. (1.75 m)
G. Overall Length	10 ft 2 in. (3.1 m)
H. Wheelbase	7 ft 6.5 in. (2.3 m)
I. Ground Clearance	8 in. (20 cm)
Platform Capacity	
3369LE	1,000 lb (454 kg)
4069LE	800 lb (362 kg)
Capacity on Platform Extension	250 lb (113 kg)
Lift/Lower Time	
3369LE	38/42 sec
4069LE	54/50 sec
Maximum Drive Height	
3369LE	Full Height
4069LE	30 ft (9.14 m)
Gross Vehicle Weight*	
3369LE	9,760 lb (4,427 kg)
4069LE	10,560 lb (4,790 kg)
Ground Bearing Pressure	
3369LE	57 PSI (4.01 kg/cm ²)
4069LE	61 PSI (4.29 kg/cm ²)

Chassis

Drive Speed-Elevated	0.4 mph (.64 kmph)
Drive Speed-Lowered	3.0 mph (4.8 kmph)
Gradeability (2WD/4WD)	35%/45%
Turning Radius (Inside)	90 in. (2.29 m)
Turning Radius (Outside)	186 in. (4.72 m)
Tire Size/Type	240/55-17.5 Non-Marking
Brakes	Spring Applied Hydraulically Released Discs

Power Source

Batteries	8 x 6V, 370 amp-hr
Charger	21 Amp, Automatic SCR Charger
Electric Pump Motor	Series Wound
Drive Motors	Two 5.5 hp Shunt Wound
Pump	Single Section Gear Pump
Hydraulic Reservoir	8.5 gal. (32.18 L)
Generator Set (Multi-power Options)	
	Fully Automatic, 45 Amp Kubota
	6 hp Air-Cooled Engine
Engine Fuel Tank	4 gal. (15.14 L)

*Certain options or country standards will increase weight.



Optional All-Wheel Drive Provides Superior Performance On or Off Slab

The JLG "1 & 5" Warranty

JLG Industries, Inc. backs its products with its exclusive "1 & 5" Warranty. We provide coverage on all products for one (1) full year, and cover all specified major structural components for five (5) years. Due to continuous product improvements, we reserve the right to make specification and/or equipment changes without prior notification. This machine meets or exceeds applicable OSHA Regulations in 29 CFR 1910.67, 29 CFR 1926.453, ANSI A92.6-1999, and CSA Standard CAN3-B354.2-M82, as originally manufactured for intended applications.



JLG Industries, Inc.
1 JLG Drive
McConnellsburg, PA 17233-9533
Telephone 717-485-5161
Toll-free in US 877-JLG-LIFT
Fax 717-485-6417
www.jlg.com

Form No.: SS-LE-504-10M
Part No.: 3131502
R060605
Printed in USA